

GERICKE FEEDOS S

PRECISION FEEDING DEVICE FOR CAPACITIES BETWEEN 0.5 AND 500 LITRES PER HOUR

Gericke's FEEDOS S is a high-precision and compact feeding device. Thanks to its modular design, it is versatile and impresses with its high adaptability to suit both the bulk material and the process. Gericke's FEEDOS S represents a new generation of feeding devices which combine simple operation with easy cleaning and minimal maintenance.



GERICKE FEEDOS S

Features and benefits

- Multi-functional use thanks to the geometry of all the components which is optimised for even material flow
- Suitable for well, moderately and poorly flowing bulk solids
- The newly designed hopper shape promotes constant product supply to the feeding tool
- The device can be stripped down in just a few steps. The individual components are lightweight and simple to handle
- Unlike the majority of devices available on the market, both the feeding tool and the feeding chamber can be removed for cleaning
- Gericke's FEEDOS S can be used volumetrically or gravimetrically
- Thanks to various feeding tools and feeding lengths, a wide range of applications can be covered

Overall there is a considerable reduction in effort in terms of cleaning and maintenance while still having a wide range of uses. This makes Gericke's FEEDOS S the optimal device for the **food, chemical and pharmaceutical industries** where, along with the highest dosing reliability, a hygienic and easy-to-maintain design is required.

Advantages

- Compact design – high dosing accuracy
- Simple and easy to disassemble, without special tools
- Adaptable thanks to exchangeable feeding tools in various sizes and lengths
- The feeding chamber shape impresses with its large radii and optimises product flow
- Segregation-free and uniform product flow to the feeding tool



- The arrangement of the feeding tool at the bottom of the feeding chamber means that there is almost complete discharge of the residue when lots are changed or prior to cleaning
- Standardised, hygienic connections to the upstream and downstream processes are dust-free and simple to operate – clamp connections rather than screwed joints
- The brackets for the feeding tool and the intramitter are not in the product area, this allows for disassembly and assembly
- Disassembly of the parts in contact with the product without reaching into the product space, in one step and in one piece is possible (no product release and risk to the staff)
- It is possible to swap the feeding chamber between different devices (e.g. for product changes without intermediate cleaning)
- Modular concept – versions with and without intramitter available, can be retrofitted if needed
- High-quality sealing systems ensure that there is no accidental discharge of bulk material



Feeding tube Tri-Clamp connection



Feeding chamber with intramitter



Feeding tool - helix

SPECIFICATIONS

Component	Model
Feed rate	0.5 - 500 l/h
Dosing tools	Rectangular Helix (optionally reinforced with centre shaft or full flight screw)
Product outlet	Feeding tube with or without vertical downspout (optionally with end bearing for helix with centre shaft or with AGP shut-off valve)
Intromitter	Optionally available, can be retrofitted
Hopper	Round cross-section Useful volumes: 5 l, 15 l, 30 l, 50 l From 15 l, optionally with agitator
Seals	Low-maintenance stuffing box (PTFE packing) Optional: Additional seal types and purge gas for all types
Connections	With flared tube end and clamping ring or with Tri-Clamp connections
Explosion protection	Devices for ATEX zones 20 (inside) 21, 22 (outside)
Materials	Parts in contact with product made of 1.4404 (316L) stainless steel
Weight	22 kg (without extra hopper)
Surfaces (product contact)	Polished Ra < 1.5 µm; optionally Ra < 0.8 µm or electropolished
Drive	AC drive motors, 0.09-0.12 kW (feeding tool) Standard - 400 V / 50Hz, IP 54, colour: RAL 9010

All dimensions in mm

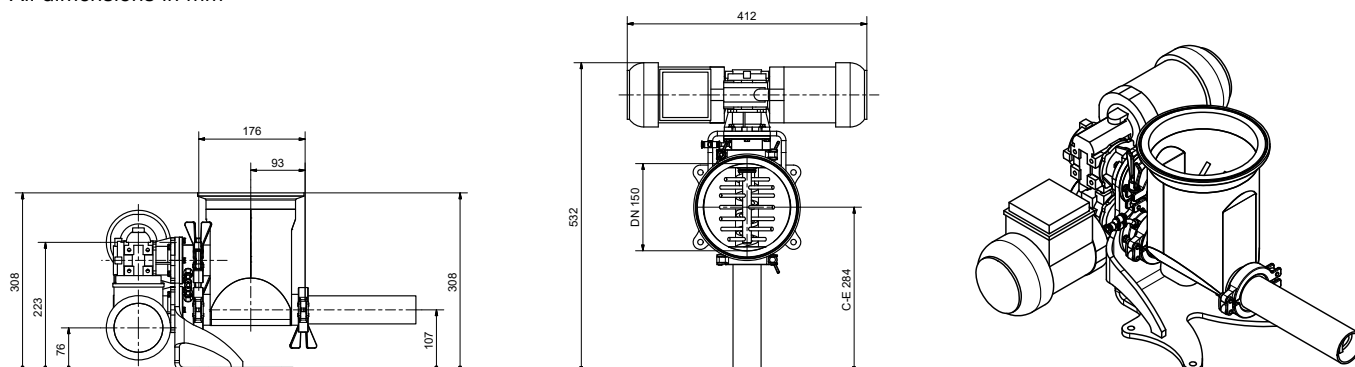

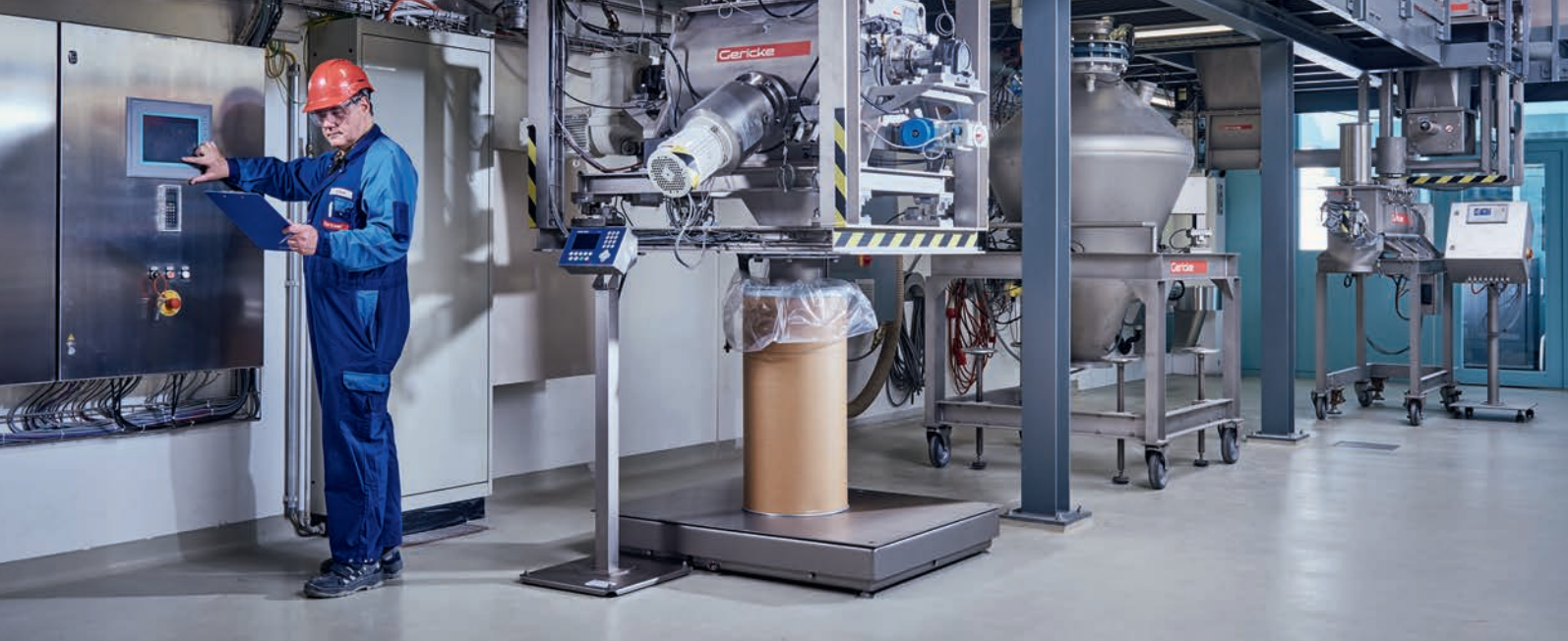

TEST CENTRE

Tests on an industrial scale reduce planning time and increase process safety!

Test centres in Switzerland, France, England, Brazil, USA and Singapore are available for customer tests under near-production conditions. The test centres are equipped with original machines. Experienced specialists design the test layout according to your wishes and perform the tests.

- Testing of machines and prototypes with original products
- Checking of performance ranges and accuracies
- Testing of the interaction of multiple machines
- Gaining of experience for product processing
- Sampling for laboratory tests and market response
- Customer training

SERVICE

Worldwide support for commissioning, maintenance and service.

We highly value punctual delivery, reliable assembly and thorough assembly monitoring. With well-planned commissioning and intensive on-site training we create the prerequisites for a smooth production start-up. Our service team and the global spare parts service combine to ensure long service life and high availability of systems with consistent product quality.

YOUR PARTNER WORLDWIDE

Switzerland

Gericke AG
T +41 44 871 36 36
gericke.ch@gericke.net

Germany

Gericke GmbH
T +49 7731 929 0
gericke.de@gericke.net

France

Gericke SAS
T +33 1 39 98 29 29
gericke.fr@gericke.net

Netherlands

Gericke B.V.
T +31 33 25 42 100
gericke.nl@gericke.net

United Kingdom

Gericke Ltd.
T +44 16 13 44 11 40
gericke.uk@gericke.net

Singapore

Gericke Pte Ltd.
T +65 64 52 81 33
gericke.sg@gericke.net

China

Gericke (Shanghai) Pte Ltd.
T +86 21 3306 3395
gericke.cn@gericke.net

Indonesia

Gericke Indonesia (Rep. Office)
T +62 21 2958 6753
gericke.id@gericke.net

USA

Gericke USA, Inc.
T +1 855 888 0088
gericke.us@gericke.net

Brazil

Gericke Brasil Ltda.
T +55 11 2598 2669
gericke.br@gericke.net

For all other countries please contact Gericke AG in Switzerland.