

BIN AERATORS

Fluidizes materials in bins, hoppers and silos, without damaging vibrations

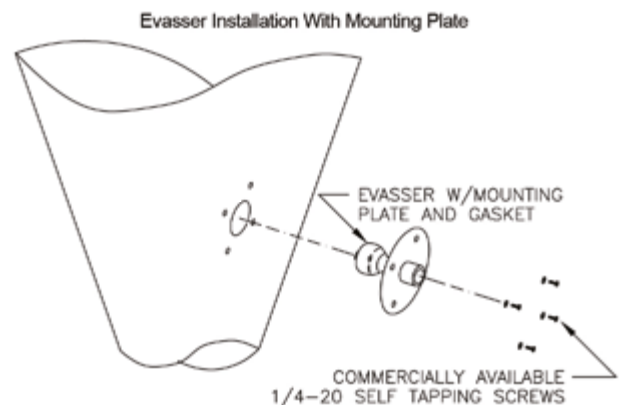

+ Applications

The most effective aeration of dry bulk materials is typically achieved by the use of four rows of Bin Aerators, one row located in each quadrant of the sloping bin bottom. With aerating dry powders the Bin Aerators will normally be spaced 18in on centers, with the lowermost units located close to the outlet where most of the bridging starts. On granular materials the location of the Bin Aerators will vary with the material being aerated and the configuration of the bin. In all cases, please consult with our application engineers that are ready to provide you with the best recommendation for your specific material flow problem.

+ Advantages

- Typical effective radius of 300 mm (12 inches)
- Easy to mount with optional external mounting plate
- Compact and low cost with virtually no maintenance
- Available in cast iron or 316 stainless steel
- Black Neoprene boot or optional white FDA Neoprene boot

+ Principle of Operation

The single Bin aerator operates by continuously introducing air into a mass of stored powder. When first conveyed into a storage vessel, the powder is a highly aerated mixture of air and particulate. In this state, the mixture flows quite easily. As the material settles, the particulate and air separate. The material decreases in volume and increases in density (it packs), and in turn it begins to behave like one solid mass rather than a fluid mixture of particles. The aerator replaces the naturally lost air and increases and maintains the air-to-particulate mixture ratio, thus allowing the material to flow.

+ Specifications

Air Supply:	Continuous clean, dry air 200 to 350 mbar (3 to 5 psid) (the difference between the air feed pressure and the internal vessel pressure)
Air Consumption:	Typically 200 mbar (3 psi) / 85 l/min (3 scfm)
Materials of Construction:	
Body:	Cast iron or 316 stainless steel
Mounting Plate (optional):	Mild steel (Option 3, 3A)
Gasket (mounting plate):	Cork (up to 80°C/175°F) for mild steel mounting plate
Boot (standard):	Black Neoprene (up to 80°C/175°F)
Boot (optional FDA):	White Neoprene (up to 80°C/175°F)
Sintered Metal Insert (optional):	Bronze 90 micron (up to 480°C/900°F) or 40 (optional) micron filter for extra fine materials (up to 480°C/900°F)
Air Inlet Connection:	1/2" NPT coupling

+ Dimensions

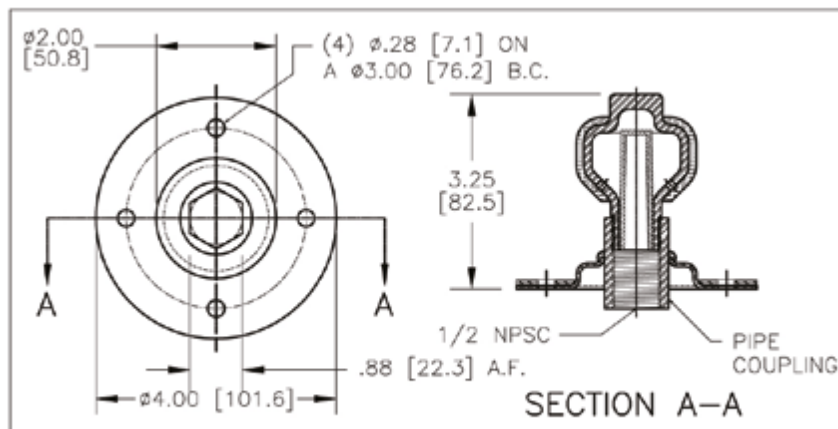

DIMENSIONS ARE SHOWN IN INCHES WITH MILLIMETER EQUIVALENT IN BRACKETS []

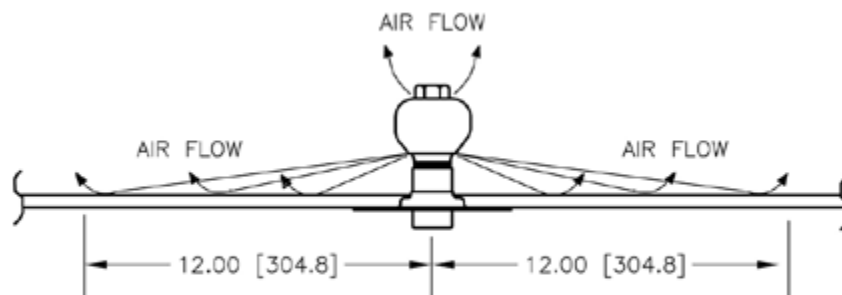

DIMENSIONS ARE SHOWN IN INCHES WITH MILLIMETER EQUIVALENT IN BRACKETS []