

Pneumatic dense phase conveying system for a Limestone Plant

Description:	Conveying system over a distance of 160 metres horizontal, 30 metres vertical lift with 6 conveying bends.
Client:	Limestone processing plant
Gericke Technology:	Continuous pneumatic dense phase PTA system with twin pressure vessel (transmitter) arrangement, each one holding 650 litres with fully automatic sequencing controls.
Application:	Conveying of powdered limestone from the production site to a remote silo over a distance of 190 metres.
Material conveyed:	Powdered limestone. (Bulk density 0.63kg/litre)
Particle size, physical properties:	3 to 4 micron. Abrasive.
Product source:	Internal bulk storage silo.
Product destination:	Via external silo to railway tankers.
Conveying rate:	20 tones per hour.
System requirements:	Dust free transfer of product with minimum wear. Totally reliable operation throughout Summer and Winter. Continuous conveying operation inside and outside the building, under variable temperature conditions.



This highly effective Gericke system has a throughput of 20 tph. The high pipeline loading makes conveying with the minimum amount of air and a small filter possible. The low conveying speed also ensures that wear is kept to an absolute minimum, and therefore special pipe bends are not required. The optimized plant layout ensures the effective and reliable transfer of product even under greatly varying temperature conditions.

Gericke

Powder Processing Equipment and Systems

The system's requirements were to convey very fine and abrasive limestone powder from a silo inside the production building, over a railway line and into the second silo at the railway loading point. The previously installed pneumatic lean phase conveying system was no longer able to meet these stringent requirements.

The Gericke dense phase PTA conveying system provided the perfect solution. Incorporating twin-transmitter vessels it met all the client's production requirements by considerably raising the output whilst at the same time reducing abrasion and wear, and also minimising the amount of air required.



Gericke provide a complete turnkey service for system implementation, including all controls, installation and commissioning.

Gericke technical staff are available to help you resolve your bulk solids handling requirements and can arrange full scale pilot system trials.

Legend:

- 1 Production building
- 2 Intermediate storage
- 3 Gericke twin-transmitter vessels
- 4 Gericke pneumatic dense phase PTA conveyor, 190 m overall length
- 5 Filter
- 6 Railway tanker loading silo
- 7 Railway tanker

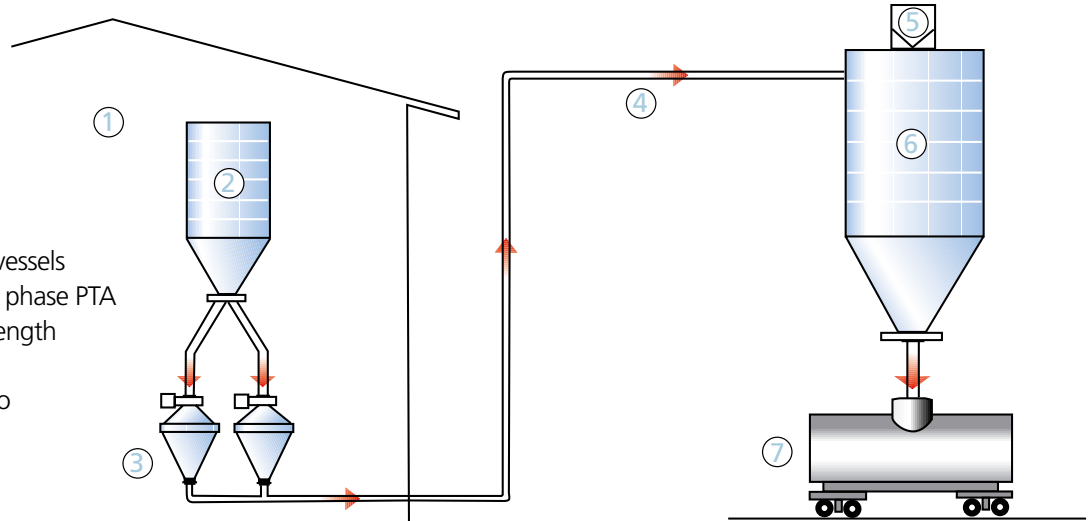

For more information on our other products, services, distributors see:

www.gericke.net

Gericke representatives:

Gericke

Powder Processing Equipment and Systems

CH-8105 Regensdorf
Tel. +41 44 871 36 36
gericke.ch@gericke.net

DE-78239 Rielasingen
Tel. +49 7731 929-0
gericke.de@gericke.net

FR-95100 Argenteuil
Tel. +33 1 39 98 29 29
gericke.fr@gericke.net

SG-787813 Singapore
Tel. +65 6452 8133
gericke.sg@gericke.net

GB-Ashton-under-Lyne
Tel. +44 161 344 1140
gericke.uk@gericke.net

NL-3870 CA Hoevelaken
Tel. +31 3325 42-100
gericke.nl@gericke.net

CN-200020 Shanghai
Tel. +86 21 538 201 08
gericke.cn@gericke.net