

# ***Gericke: Type RA silo and bin discharger***

**Designed for bulk materials with  
medium to poor flow characteristics**



## **Applications include:**

- Discharging and feeding from silos and hoppers into dense phase and lean phase pneumatic conveying systems
- Fast loading of loss-in-weight feeders with integral outlet valve for complete product flow isolation
- Component feeding into weigh hoppers or batch mixers
- Discharging from blended product hoppers without segregation
- Multit-outlets (up to 4) for distribution to more than one point including:
  - mills and mixers
  - FIBC big bag or sack fillers
  - filling machines
  - containers and drums
  - mainstream processing
  - re-cycling

# Discharging, feeding, isolation valve, distribution

## Maximising storage volume with limited headheight

Model	Internal diameter dimension 'A'	Outlet capacity TPH *
550	550	0,2 to 20
800	800	0,2 to 40
1200	1200	1 to 40

\* throughput is dependant on product bulk density, speed of machine etc.

### Type RA

Unit constructed with top flange for direct connection to the silo or hopper, variable output rate with manual adjustment. Agitator mounted onto a rotating shaft with integral geared motor unit. 'V' ring shaft seals with air purge option.

### Type RAS

Machine designed for wet cleaning operations and over/under pressure applications with gland packed seals.

### Type RAHD (model 1200)

Heavy duty version for silo applications up to 80 tonnes. 2 options available:

- Knife gate valve (used for general applications)
- Pneumatically operated plunger valve (used for poor flowing products)

### Machine options

- Additional outlet (1 to 4)
- Pneumatically actuated outlet valve
  - Fully opened and closed
  - Settings for midway opening for dribble feeding
- Air purged seals
- Inspection/cleaning lid at outlet
- Right angle drive

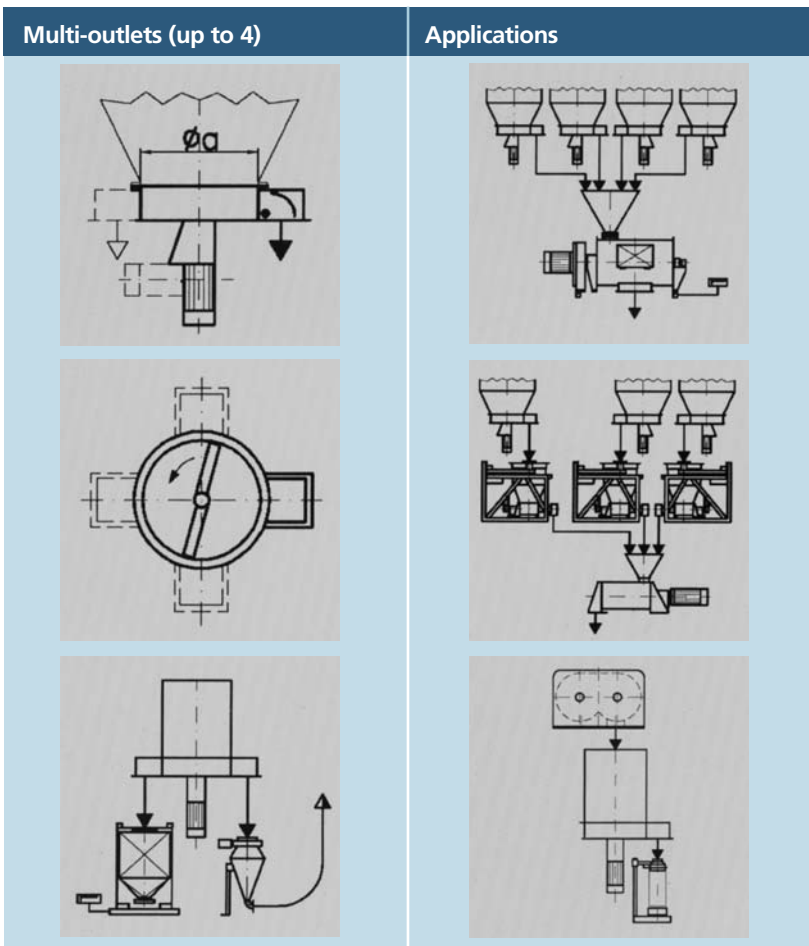

For more information on our other products, services, distributors see:

[www.gericke.net](http://www.gericke.net)

Gericke representatives:

# Gericke

Powder Processing Equipment and Systems

**CH**-8105 Regensdorf  
Tel. +41 (0) 44 871 36 36  
gericke.ch@gericke.net

**DE**-78239 Rielasingen  
Tel. +49 (0) 7731 929-0  
gericke.de@gericke.net

**FR**-95100 Argenteuil  
Tel. +33 (0) 1 39 98 29 29  
gericke.fr@gericke.net

**GB**-Ashton-under-Lyne  
Tel. +44 (0) 161 344 1140  
gericke.uk@gericke.net

**NL**-3870 Hoevelaken  
Tel. +31 (0) 3325 42-100  
gericke.nl@gericke.net

**SG**-787813 Singapore  
Tel. +65 6452 8133  
gericke.sg@gericke.net